

Essences of unlike Controllers (Proportional, Proportional & Integral, Proportional & Derivative and Proportional, Integral & Derivative) on One Area Power System: A Feigning Approach

Vishwa Ranjan¹

¹Department of Electrical and Electronics Engineering, A K G Engineering College, Ghaziabad, India

E-mail: ranjanvishwa293@gmail.com

ABSTRACT

Through control hypothesis, new mathematical proficiency gives the potential to control more exactly, significantly the composite dynamical arrangements than the genuine fly ball governor. These schemes include recent trends in optimal check in the 1950s and 1960s, followed by advancements in stochastic, robust, adaptive and optimal control methods in the 1970s and 1980s. As we know that the whole substation automation depends on substation desegregation, the specifications are most commonly used interchangeably. As of, a power grid requires that generation and load closely counterweight moment by moment, frequent balancing to the turnout of generators are compulsion. The equilibrium can be checked by evaluating the system frequency; if it is heightening, more power is being generated than used, and all the machines in the system are accelerating. If the system frequency is diminishing, more loads are on the system than the current generation can allow for, and all generators are falling down for sure. In this paper, a pictorial as well as hypothetical approach is put in use to show a basic difference between different types of controllers which are proportional, proportional and derivative, proportional and integral, proportional and derivative and integral controllers and correspondingly their effect in terms of controlling on one area power system is depicted and thoroughly studied and examined.

KEYWORDS: *Automatic Generation Control, Controllers, Control Area, Fuzzy Logic Controllers, Load Frequency Control*

1. INTRODUCTION

Automatic control systems are usually used as it does not constitute manual controlling. The controlled variable quantity is measured and compared with a specified value to obtain the desired result. As a result of automated systems for control purposes, the cost of energy or power as well as the cost of process will be diminished thereby enhancing its quality and productivity. Controllers amend steady state accuracy by suppressing the steady state errors. As the steady state accuracy amends, the stability also improves. They also assist in lessening the offsets which are produced in the system. Maximum possible overshoot of the system can be controlled through these controllers. They too aid in bringing down the noise signals produced in the system. Slow response of the over damped system can be constituted much faster with the support of these controllers.

Modern day power systems are categorized into various areas. In India, there are five regional grids which are Eastern Region, Western Region, Northern Region, Southern Region and North Eastern Region. For each one of these, areas are usually interconnected to its neighboring areas. The transmission lines that connect an area to its neighboring area are called Tie Lines. Power sharing between two areas occurs via these Tie Lines. Load frequency control, as the name signifies, regulates the power flow between different areas while holding the frequency constant.

Overall, we can express that the load frequency control (LFC) has the following objectives: It holds the frequency constant ($\Delta f = 0$) against any sudden load change and each area should contribute to absorb any load change such that frequency does not deviate and every area should maintain the tie-line power flow to its pre-specified value and should not deviate from that.

2. MAINTENANCE OF SCHEDULED FREQUENCY

Let us analyze the problem of controlling the power yield of the generators of a closely knit electric area so as to balance the scheduled frequency. All the generators in that area constitute a coherent group so that all the generators speed up and slow down together preserving their relative power angles. Such an area is called Control Area. The boundaries of a control area are usually going to coincide with that of an individual Electricity Board.

Automatic Generation Control (AGC) is a crucial function in modern Energy Management Systems (EMSs). The successful functioning of interconnected power system needs the matching of total generation with that of total load demand and associated system losses. As the demand deviates from its nominal value with an unforecasted small amount, the operating point of power system does not remain the same and therefore system might experience deviations in nominal system frequency and scheduled power exchanges. The main aim of Automatic Generation Control is to maintain system frequency at or very close to a

specified nominal value and to balance the correct value of interchange power between control areas.

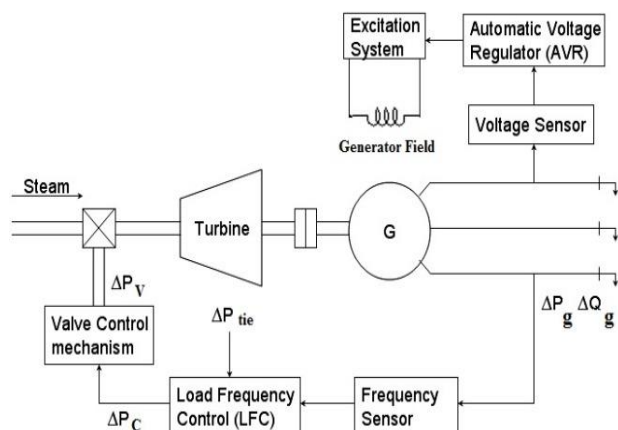

Figure.1 shows schematic diagram of load frequency and excitation voltage regulators of a turbo generators.

A literature review depicts that the systems realized for AGC were of single area thermal or hydro and/or two area thermal-thermal or hydro-thermal. Furthermore, the thermal systems considered normally non-reheat type turbines and as a result, comparatively lesser concentration has been dedicated to the AGC of thermal system with reheat type turbines. In context with the current power scenario, compounding of multi-source generators in a control area with their respective participation factors is excessively realistic for the study of LFC. The control area might have the compounding of thermal, hydro, gas, nuclear, renewable energy sources, etc.

3. TYPES OF CONTROLLERS AND THEIR SPECIFICATIONS

They are as follows-

- **Proportional Controllers**-In this type of controller, the output signal (also called the actuating signal) is directly proportional to the error signal. Proportional controller assists in lessening the steady state error, thus making the system more stable. Slow response of the over damped system can be made quicker with the help of these controllers. Due to bearing of these controllers we do have some offsets in the system. Proportional controllers also enhance the maximum overshoot of the system.
- **Derivative Controllers**-In this type of controller, the output signal (also called the actuating signal) is directly proportional to the derivative of the error signal. Some of its disadvantages are that it doesn't improve the steady state error; it creates saturation effects and also amplifies the noise signals produced in the system. The major advantage of derivative controller is that it enhances the overall transient response of the system.

- **Integral controllers**-In this type of controller, the output signal (also called the actuating signal) is directly proportional to the integral of the error signal. Due to their unique capability, the integral controller can return the controlled variable back to the exact set point after a disturbance therefore these are also known as reset controllers. Disadvantage of Integral Controller is that it inclines to make the system unstable because it reacts tardily towards the produced error.

- **Proportional and Derivative Controllers**-As the name suggests, this type of controller is a combination of proportional and a derivative controller. The output signal (also called the actuating signal) is equals to the addition of proportional and derivative of the error signal. Advantages and disadvantages are the compounding of advantages and disadvantages of proportional and derivative controllers.

- **Proportional and Integral Controllers**-As the name suggests, this type of controller is a combination of proportional and an integral controller. The output signal (also called the actuating signal) is equal to the summation of proportional and integral of the error signal. Advantages and disadvantages are the combinations of the advantages and disadvantages of proportional and integral controllers.

- **Proportional Derivative and Integral Controllers**- K_p , K_i , and K_d , all non-negative, denote the coefficients for the proportional, integral, and derivative terms, respectively (sometimes denoted P, I, and D). Here, P responds for current values of the error (e.g. if the error is large and positive, the control variable will be large and negative), I responds for past values of the error (e.g. if the output is not capable to lessen the size of the error, the control variable will compile over time, thus making the controller to apply a stronger action), and D responds for potential future values of the error, formulated on its present rate of change. As a PID controller relies only on the measured process variable, not on knowledge of the underlying process, it is generally applicable. By proper tuning of the three parameters of the model, a PID controller can manage the specific process requirements in a much better environment.

4. SINGLE AREA SYSTEM

The frequency which deviates with load is counterpointed with reference speed setting. The frequency can be adjusted to the expected value by making generation and demand equal with the assistance of steam valve controller which regulates steam valve and supplements power output from generators. It acts as the primary reason

of maintaining the real power by balancing turbine output as per that of the deviation in load demand.

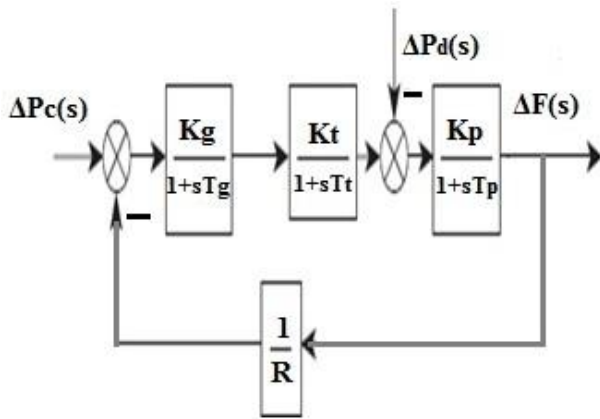

Figure.2 shows the Automatic Load Frequency Control (ALFC) loop.

5. SIMULATION RESULTS

The Matlab Simulation diagram for Single Area Power Systems is examined and consecutively the effects of availing different types of controllers are foreseen.

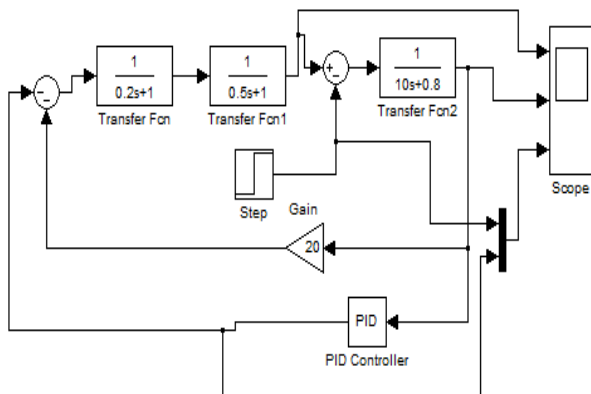

Figure.3 shows Simulation diagram for Single Area Power Systems in Mat Lab Environment.

Name	Kg	Tg(s)	Kt	Tt(s)	H(s)	D(p.u. MW/Hz)	1/R	K1
Value	1	0.20	1	0.50	5	0.8	20	7

Table: 1 System parameters for single area system by using secondary control

FOR PID CONTROLLERS-

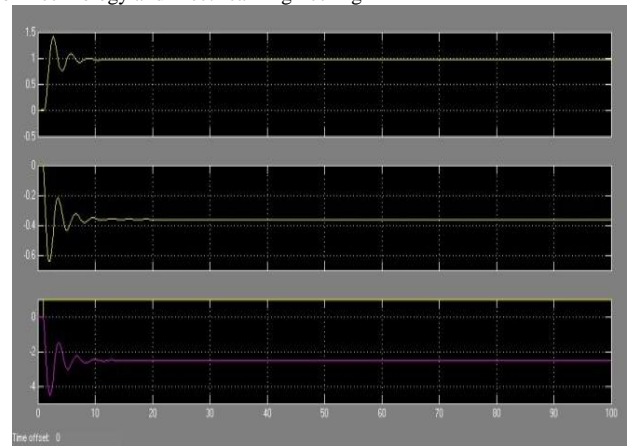

Figure.4 shows the change in turbine output (p.u.) vs. time (sec), change in frequency (Hz) vs. time (sec) and change in incremental speed reference signal (Del Pref.) vs. time (sec).

FOR PD CONTROLLERS-

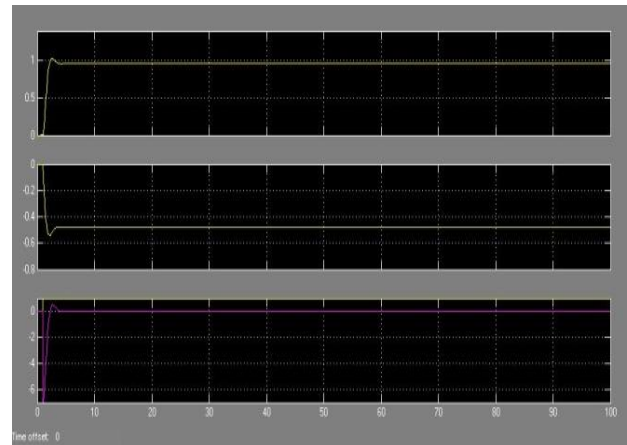

Figure.5 shows the change in turbine output (p.u.) vs. time (sec), change in frequency (Hz) vs. time (sec) and change in incremental speed reference signal (Del Pref.) vs. time (sec).

FOR PI CONTROLLERS-

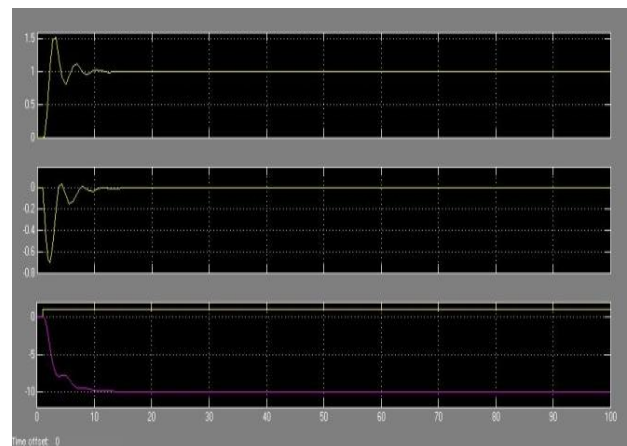

Figure.6 shows the change in turbine output (p.u.) vs. time (sec), change in frequency (Hz) vs. time (sec) and change in incremental speed reference signal (Del Pref.) vs. time (sec).

FOR P CONTROLLERS-

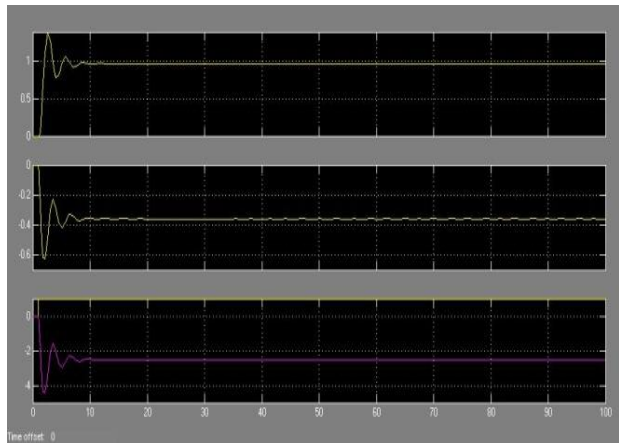

Figure.7 shows the change in turbine output (p.u.) vs. time (sec), change in frequency (Hz) vs. time (sec) and change in incremental speed reference signal (Del Pref.) vs. time (sec).

6. CONCLUSION

PID controller normally has to maintain all three-gain effect to the whole system and may negotiate the transient response, such as settling time, overshoots, and oscillations. The system can be examined, tried and proved for Two Area Control Systems. If the system parameters cannot be exactly estimated or accomplished, the designed PID gains might not protest the uncertainties and disturbances, and thus current low robustness. A proportional controller will have the burden of diminishing the rise time and will reduce but never eradicate the steady state error. An integral control will have the essence of eliminating the steady-state error for a balance or step input, but it may make the transient response dragging and decelerating. A derivative control will have the essence of enhancing the stability of the system, suppressing the overshoot, and amending and bettering the transient response. Fuzzy Logic Controllers can be used in place of conventional controllers as they have better stability, small overshoot, and fast response.

7. REFERENCES

- [1] K. Vijaya Kumar, V. Lakshma Naik, A. Suresh Babu, "A Novel Method to Improve the LFC in Single Area and Two Areas Power System Using PI Controller", International Journal of Science and Research (IJSR), ISSN (Online): 2319-7064
- [2] Atul Ikhe, Anant Kulkarni, Dr.Veeresh, "Load Frequency Control Using Fuzzy Logic Controller of Two Area thermal-thermal Power System", International Journal of Emerging Technology and Advanced Engineering, ISSN 2250-2459, Volume 2, Issue 10, October 2012
- [3] G. Konar, K. K. Mandal, and N. Chakraborty, "Two Area Load Frequency Control Using GA Tuned PID Controller in Deregulated Environment", Proceedings of the International Multi Conference of Engineers and Computer Scientists, IMECS 2014, March 12 - 14, 2014, Hong Kong
- [4] K Smriti Rao, Ravi Mishra, "Comparative study of P, PI and PID controller for speed control of VSI-fed induction motor", 2014 IJEDR | Volume 2, Issue 2 | ISSN: 2321-9939
- [5] M. Nagendra, Dr. M.S. Krishnarayalu, "AGC And AVR of Multi area power systems with and without GRC Nonlinearity", International Journal of Advanced Research in Electrical, Electronics and Instrumentation Engineering, Vol. 2, Issue 6, June 2013
- [6] S.Paliniyappan, I.Ilayaranimangammal, "An Optimistic Solution Technique For Economic Load Dispatch Problem Using Immune Inspired Algorithm", International Journal of Advanced Research in Electrical, Electronics and Instrumentation Engineering, Vol. 2, Issue 12, December 2013
- [7] Sukhwinder Singh Dhillona, Jagdeep Singh Latherb, Sanjay Marwahac, "Multi area load frequency control using particle swarm optimization and fuzzy rules", 3rd International Conference on Recent Trends in Computing 2015(ICRTC-2015), Procedia Computer Science 57 (2015) 460 – 472
- [8] M. Lokanatha, K. Vasu, "International Journal of Engineering Research & Technology", Vol. 3 - Issue 11 (November - 2014)
- [9] Gaurav, Amrit Kaur, "Comparison between Conventional PID and Fuzzy Logic Controller for Liquid Flow Control: Performance Evaluation of Fuzzy Logic and PID Controller by Using MATLAB/Simulink", International Journal of Innovative Technology and Exploring Engineering (IJITEE), ISSN: 2278-3075, Volume-1, Issue-1, June 2012
- [10] B. NAGU, NAVANEETHA. A, P.V. R. RAO, "Improvement of Power System Stability using Fuzzy Logic based HVDC Controls", Recent Researches in Energy & Environment
- [11] İsmail H. Altas and Jelle Neyens, "A Fuzzy Logic Load-Frequency Controller for Power Systems", International Symposium on Mathematical Methods in Engineering MME-06, Cankaya University, Turkey, April 27-29, 2006
- [12] B. Venkata Prasanth, Dr. S. V. Jayaram Kumar, "Load Frequency Control For a Two Area Interconnected Power System Using Robust Genetic Algorithm Controller", Journal of Theoretical and Applied Information Technology, 2005 – 2008.
- [13] Elakkiya.T, Dr.R.Jayashree, Mrs.S.Jennathu Beevi, "Load Frequency Control in Power System using Internal Model Control Technique", IOSR Journal of Mechanical and Civil Engineering (IOSR-JMCE), e-ISSN: 2278-1684, p-ISSN: 2320-334X, PP 54-60
- [14] Naimul Hasan, "An Overview of AGC Strategies in Power System", International Journal of Emerging Technology and Advanced Engineering, ISSN 2250-2459, Volume 2, Issue 8, August 2012.

AUTHOR PROFILE

Vishwa Ranjan received the degree of Bachelor of Technology from Hindustan College Of Science and Technology, Mathura, Uttar Pradesh, India in the year 2013. During this course, he was the technical head of his branch group ZEETA (Zone Of Electrical and Electronics Technical Associates). Currently, he is a research student and is pursuing Master of Technology in Electrical Power and Energy Systems from Ajay Kumar Garg Engineering College, Ghaziabad, Uttar Pradesh, India. He has an interest in Basic System Analysis, Numerical Analysis & Systems, Linear Control Systems and Power Systems.