

## Comparative Study of TEM and LEM Based Power Factor Pre-Regulator

<sup>1</sup>R.Rashmi, <sup>2</sup>Shweta Jagtap

<sup>1,2</sup> Department of Instrumentation science, Savitribai Phule Pune University, India

E-mail: [ruchirashmi@gmail.com](mailto:ruchirashmi@gmail.com), [shweta.jagtap@gmail.com](mailto:shweta.jagtap@gmail.com)

### ABSTRACT

Most of the traditional switch mode power supplies (SMPS) are designed without the pre-regulator power factor correction (PFC) circuit to minimize the cost. However, due to low power factor (PF), extra current is required to drive the similar load, results in lower efficiency, larger size of components and increased cost of an overall system. In high power applications, to fully utilize the line, power factor correction (PFC) is a necessity. In this paper high power PFC pre-regulator circuit of 1KW is designed and simulated. Further the comparison of the two modulation techniques trailing edge modulation (TEM) and leading edge modulation (LEM) is carried out to analyze its effect on PF and harmonic content of input current. LEM controller shows better results in term of higher PF and lowers THD. In LEM controller, the electrolytic capacitor used to store the output voltage is also of smaller size as compared to TEM but it suffers from high overshoot of output voltage at start-up condition. The PF achieved in TEM and LEM controller is 0.98 with current harmonics of 5.33% and 0.99 with current harmonics of 2.18% respectively.

**Keywords:** Power Factor, Total Harmonic Distortion, Trailing edge modulation, Leading edge modulation

### 1. INTRODUCTION

Generally power supplies have small conduction angle that draws current in pulses to drive the load. SMPS acts as a nonlinear load to the power source and creates harmonic pollution. To maintain green power, IEC standards [1] such as IEC/EN61000-3-2 and IEC/EN61000-3-12 mandates the development of efficient PFC by regulating the line current harmonics within the set limits. The imposed IEC conditions increase the requirement of high-performance power factor correction pre-regulator for power supplies to improve input power quality. To design a PFC pre-regulator many pulse-width modulation schemes are applied such as Double edge modulation (DEM), LEM, and TEM to control the desired parameter. In generalized PWM scheme, a constant frequency PWM signal is generated by the magnitude comparison of a reference signal  $r(t)$  with the carrier signal  $c(t)$ . The carrier signal presented in DEM, TEM, LEM are a triangular waveform, saw tooth waveform and reverse sawtooth waveform respectively. Both TEM and LEM reduce the ripple current under the proper synchronization with the down regulator. The lower ripple current also decreases the size and cost of the storage capacitor. TEM modulation technique is simple and easy to implement as PWM output can easily be disabled by pulling the signal to ground. But TEM controller can easily be affected by the noise signal and has higher current distortion. To overcome these issues, LEM converter is used which provides better PFC and lower current harmonics. These modulation techniques can easily be verified with the easily available PFC controllers while for implementation of advanced modulation technique such as cuckoo search algorithm, neural network [2], probabilistic neural network (PNN) [3], harmonic elimination pulse-width modulation [4] and many more, require DSP or FPGA based programmable controllers which will make the system complex and costly. Current controlled buck converter is used

for the PFC of Brushless DC motor [5] without the requirement of down regulator. However, buck converter has its own disadvantage like discontinuity in the inductor current which decreases the PF. Active current injection rectifier method is used to achieve high power factor by inducing the harmonic current components [6] which results in low THD. Stepins and Huang D. [7] has shown that switching frequency modulation could also worsen the PF if proper modulation frequency is not used and analyzed result is verified with modulating signal of sine, triangular and sawtooth wave form. R. A. Rani et al. [8] has concluded that input voltage needs to be increased and vice versa, if the load contains more reactive power than the real power. This is due to absence of feed forward network [9], But in this study due to the addition of feed forward loop, power factor and voltage remains regulated even with the change of input voltage. TEM and LEM control techniques with the feedforward loop is also used by many researchers to increase the PF. In voltage regulator battery energy storage system, the PFC and output voltage is regulated using the TEM controller [10]. A PFC pre-regulator based on TEM controller is designed [11] with the down regulator. The harmonics current distortion is minimized using the LEM controller in aircraft power system [12]. For low to medium power range, the boost converter is usually designed in discontinuous mode (DCM) and Critical conduction mode (CrCM). But in this paper for high power, CCM mode is chosen as it has a low root mean square (RMS) current as compared to CRM and DCM. Further it has relatively low inductance which results in low inductor peak current and less stress on the devices [13].

This paper is structured as follows: TEM and LEM modulation techniques are presented in section 2. Further, the Design of pre-regulator boost PFC with analog control is discussed in section 3. The simulation results of PFC pre-regulated circuits are compared and verified in section 4. Conclusion and future research needs are presented in section 5.

## 2. PRINCIPLE OF MODULATION TECHNIQUES

Pulse width modulation (PWM) is the preferred way to drive modern semiconductor power devices. Among the PWM techniques, TEM is the most common modulation techniques applied in power electronics. As shown in Figure 1 [14] sawtooth voltage waveform and error voltage signal are compared. In TEM, the trailing edge and in LEM, the leading edge of the sawtooth waveform occurs at a fixed instant and the generated PWM modulates with the variation of an instantaneous error signal. In TEM, the duty cycle is determined by a controlled on-time.  $V_{gs} = \text{High}$  if  $V_{saw} < V_{ic}$  while in LEM, the duty cycle is determined by a controlled off-time.  $V_{gs} = \text{Low}$ , if  $V_{saw} < V_{ic}$ , Where  $V_{gs}$  = Mosfet gate to source Voltage,  $V_{saw}$  = sawtooth signal,  $V_{ic}$  = Reference signal. LEM operates in inverse logic of TEM which increases the noise immunity against the high frequency switching noise.

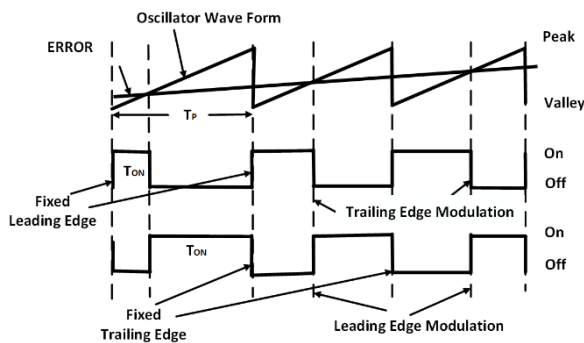

Figure 1. Trailing edge and leading edge PWM [14]

## 3. DESIGN OF PRE-REGULATOR BOOST PFC

B.Singh, S.Singh, Chandra and Al-Haddad [15] has compared several topologies and observed that PF of the boost converter is higher as compared to the buck converter. So in this paper, a boost PFC pre-regulator circuit of high power factor is designed in PSIM software around TEM based UCC3854 and LEM based UCC2817 to curb the harmonic pollution. 1KW PFC pre-regulator circuit is designed with the requirements as shown in Table-1.

### 3.1 BOOST TOPOLOGY DESIGN

As shown in Figure 2 (a). When Q1 is closed, current flows through the inductor L and stores energy. Because of the voltage polarity, the diode D is reverse biased. When the switch Q1 is open as shown in Figure 2(b), inductor L reverses polarity because of the collapsing magnetic field. The D becomes forward-biased and induces a current flow  $I_c$  in the polarity shown in fig. The energy is stored in the inductor during the switch on period, then this energy is transferred to the load during the switch off period.

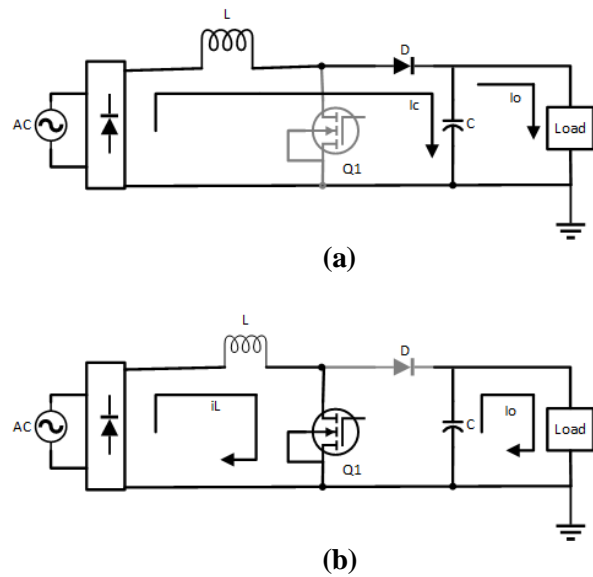

Figure 2. Circuit configuration of pre regulator boost converter: a) ON-state, b) OFF-state.

The switching frequency is selected to be 100KHz to get a tradeoff between component size and the switching loss. As for the standard 220Vrms, the output voltage must be greater than the highest peak input voltage of 382V in boost topology so the design requirements of the output voltage is set to be 400V for the application in field of electrical vehicle charger. The output capacitor is chosen to be 1800 $\mu$ f and 820 $\mu$ f in TEM controller and LEM controller respectively to get a holdup time of 34msec. In LEM modulation technique, smaller value of the capacitor is chosen due to pre-reduction of ripple in reverse logic. Maximum peak line current, ripple current are same in both controllers. The maximum multiplier input current applied in TEM and LEM controllers is 600mA and 500mA respectively [9,16].

Table 1. Circuit parameters of simulation

Parameters of PFC stage	Values( TEM and LEM)
Rectified line voltage $V_{in,rms}$	220Vrms,50Hz
PFC pre-regulator DC output voltage $V_{PFC}$ ,	400V
Switching frequency $f_{sw1}$	100kHz
Inductance L	1mH
Output capacitance C	1800 $\mu$ F(TEM)and 820 $\mu$ F(LEM)
Maximum power	1kW
Maximum peak line current ( $I_{pk}$ )	17.68A
Ripple current of Inductor	3.6A

### 3.2 CONTROL DESIGN

The circuit includes the inner current loop and the outer voltage loop and feed forward control loop as shown in Figure 3 [9]. The outer loop controls the average amplitude of the

inductor current to regulate the output voltage. It is designed as a low-frequency voltage loop [17]. The voltage control loop acquires the instantaneous output voltage from the precise sense resistor ( $R_{sense}$ ). The inner loop is designed as a high-frequency current loop. The current loop shapes the rectified line current to make converter appearance as a purely resistive circuit to the line. The loop compares the instantaneous signal of inductor current ( $i_L$ ) to the reference signal ( $I_{ref}$ ). This reference signal is created by multiplying the rectified line voltage with the output of the voltage error amplifier to achieve the shape of the input voltage and amplitude proportional to the desired output voltage. With the addition of feed forward line regulation ( $1/VFF^2$ ) term at the input of the multiplier, the input voltage change does not warrant a change in  $V_{out}$  for a given load. The PFC pre-regulator operates in a continuous and discontinuous mode under high and low load respectively with the current multiplier approach without a performance change.

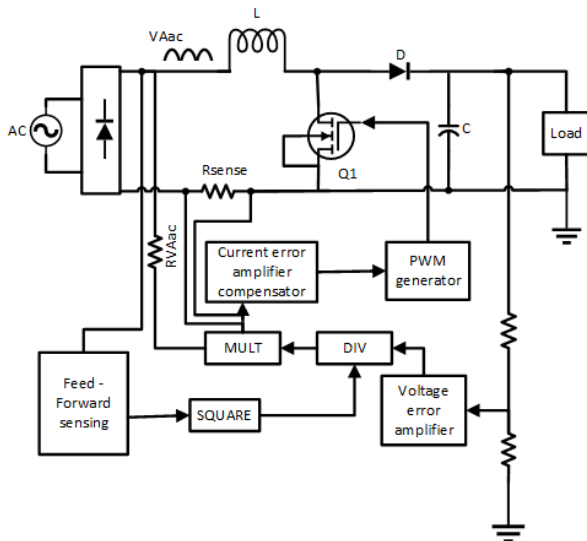

Figure 3. Basic block diagram of BOOST PFC [9]

In TEM and LEM controller, the  $i_L$  rises and falls linearly with a slope of  $1.3A\mu s^{-1}$ . The  $R_{sense}$  resistor is chosen to be  $0.051\Omega$  so the input to the current error amplifier is  $67mV \mu s^{-1}$ . An current error is compared with the oscillator ramp signal of  $5.2V$  peak to peak with a slope of  $0.52V\mu s^{-1}$ . A single pole voltage loop is used to minimize the line current distortion. Voltage control loop bandwidth is kept as  $19.1Hz$  lower than the line frequency of  $50Hz$  to protect the modulation of the input current during the regulation of the output voltage. The current loop of higher bandwidth  $10.46 kHz$  is designed in order to follow the rectified sinusoidal references. If lower crossover frequency is chosen, a zero-crossing distortion may occur because of slow slew rate. In this distortion the input current lags behind the  $I_{ref}$  at zero crossing of AC line input for short duration. This lag time depends on the inductor value, a smaller value of inductor gives better tracking, low harmonic distortion, high PFC but with high ripple current.

The LEM controller provides noise immunity since the multiplier result is applied to the input of the inverting

terminal of the current amplifier, which inverts the signal by  $180^\circ$ . It reduces the output capacitor size and electromagnetic interference (EMI). The output capacitor stores and releases the energy during PWM cycles results in rippled output voltage.

#### 4. Experimental verification

The simulation is carried out for a  $1KW$  single phase power supply with  $400V$  DC output and load current of  $2.8A$ . This designed power supply is tested with single phase input supply voltage of  $220V$ ,  $50Hz$ . The oscillator ramp and compensator output versus time for controller TEM and LEM are shown in Figure 4 and Figure 5 respectively. These figures verify the basic working principle of TEM and LEM techniques as mentioned in Figure 1. The trailing edge of PWM gets modulated based on the reference current in TEM controller and the leading edge of the PWM gets modulated based on the reference current in LEM controller.

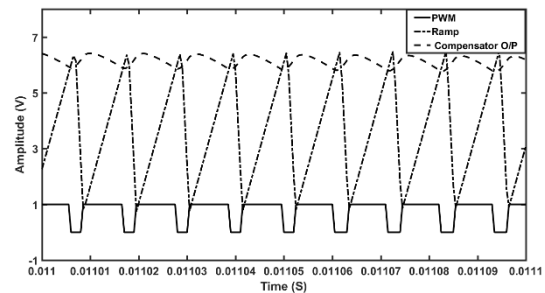

Figure 4. Oscillator ramp, compensator output and PWM versus time for TEM controller

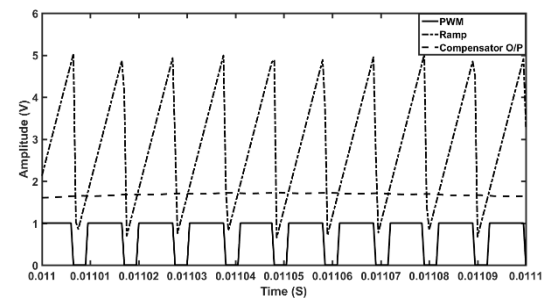

Figure 5. Oscillator ramp, compensator output and PWM versus time for LEM controller

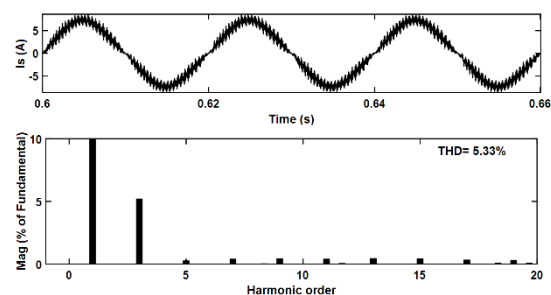
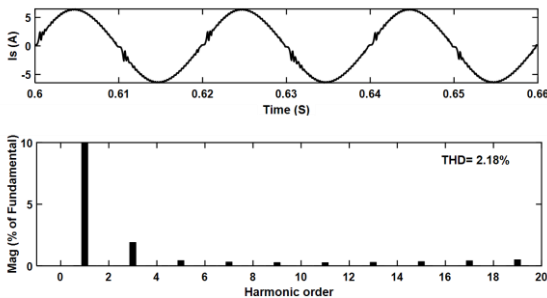

Figure 6. Input current harmonics in TEM controller

Figure 6 shows the presence of harmonic contents in input current for TEM controller. The upper half of the figure shows the distorted input current variation with time. The lower half of figure shows the frequency domain analysis of input current where amplitude of 2<sup>nd</sup> to 20<sup>th</sup> order of harmonic is mentioned. It is seen from the figure that the even harmonics are absent as the generated current waveform is symmetrical about the time axis. The amplitude of the 3<sup>rd</sup> order harmonic is 5.21%, 5<sup>th</sup> order harmonic is 0.029% and 7<sup>th</sup> order harmonics is 0.41%.



**Figure 7. Input current harmonics in LEM Controller**

Figure 7 shows the harmonic contents of the input current in LEM controller. It is also observed that the shape of the input current waveform is more similar to the pure sine wave as compared to the TEM controller in steady state due to the presence of lower harmonics. The amplitude of the 3<sup>rd</sup> order harmonic is 1.91%, 5<sup>th</sup> order harmonic is 0.44% and 7<sup>th</sup> order harmonics is 0.32%. Low harmonics increases the performance of the power supply and decreases the premature ageing due to poor functioning of the power supply.

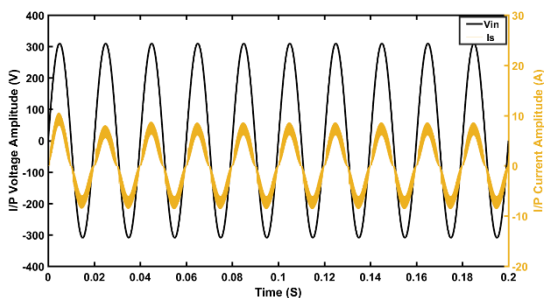

**Figure 8. Waveform of input current and input voltage in TEM controller**

Figure 8 shows the waveform of input current and input voltage versus time in TEM controller which clarifies the phase angle between them. On the left axis, input voltage and on the right axis input current is scaled. This figure shows the input voltage and input current are in phase with a power factor of 0.983.

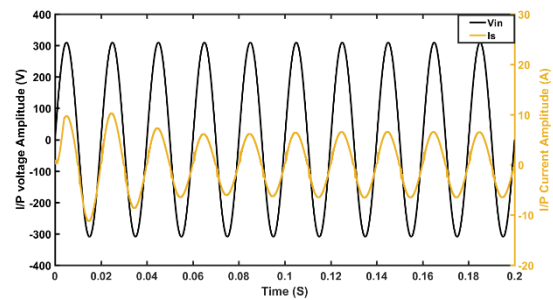

**Figure 9. Waveform of input current and input voltage in LEM controller**

Figure 9 shows the waveform of input current and input voltage versus time in LEM controller which clarifies the phase angle between them. On the left axis, input voltage and on the right axis input current is scaled to show the phase angle. Here Power factor is observed to be 0.993. LEM controller provides higher power factor due to the improved feedforward regulation and noise immunity.

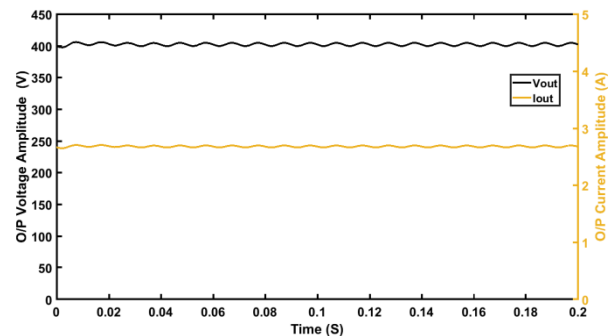

**Figure. 10. Output voltage and load current in TEM controller**

Output voltage and current using TEM controller of PFC pre-regulator circuit is shown in Figure 10, where the output voltage is regulated at the 400V and the load current is 2.8A. The Output ripple voltage is 4.98V and the ripple current is 0.14A. Here on the left axis scaling of output voltage is shown and on the right axis the scaled load current is shown.

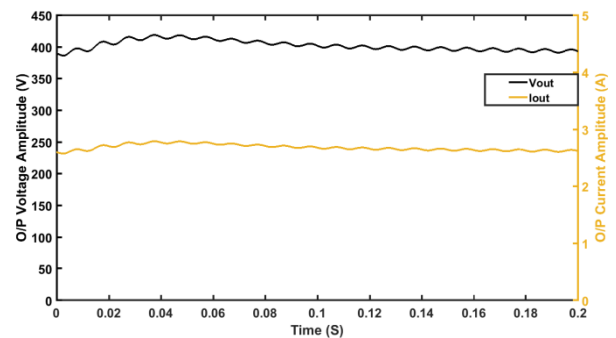

**Figure. 11. Output voltage and load current in LEM controller**

Output voltage and current using LEM controller of PFC pre-regulator circuit is shown in Figure 11, where the output

voltage is regulated at the 400V and the load current is 2.8A. The Output ripple voltage is 10V and the ripple current is 0.10A. Here on the left axis scaling of output voltage is shown and on the right axis the scaled load current is shown. Here the LEM control has higher overshoot as compare to the TEM controller due to the inverse logic.

The power quality indicators such as presence of total harmonic content in AC mains current (THDi), power factor (PF), crest factor (CF), distortion factor (DF), displacement power factor (DPF) and output voltage ripple ( $\Delta V_o$ ) are compared at full load in Table 2. It can be seen that the input current in these converters meets IEC-61000-3-2 standard requirements.

Parameters	TEM	LEM
1. THDi(% of Is)	5.33	2.18
2. DF	0.999	0.998
3. DPF	0.984	0.995
4. PF	0.983	0.993
5. CF	1.414	1.414
6. $\Delta V(V)$	4.98	10

**Table 2. Power quality parameters**

## 5. Conclusion

In this paper, a non-isolated boost converter based average current-mode control PFC regulator is designed. The designed pre-regulator provides continuous input current due to which to the shape of the input current waveform is maintained with the low noise. The pre-regulator boost converter is controlled by a double loop scheme which provides a high level of power quality at AC mains with low ripple and well regulated DC output. THD, DF, DPF, PF and CF is compared for TEM and LEM controllers. It is observed that the LEM controller results in less-distorted input current than TEM controller but with high overshoot at startup condition. Hence extra protection circuit for soft start and duty cycle limit should be added while designing the modulation technique based on LEM. To get the advantage of TEM and LEM [18], both controllers can be used together to regulate the different stages of the power supply.

## REFERENCES

- [1] IEEE Std. (The Institute of Electrical and Electronics Engineers Standards Association), 2014 IEEE Recommended Practice and Requirements for Harmonic Control in Electrical Power Systems, IEEE Std. 519-2014
- [2] M. Sahithullah M. & A. Senthil Kumar (2016) A Hybrid Control Strategy to Control Active Filter and Improve the PQ of Non-Linear Load, Australian Journal of Electrical and Electronics Engineering, 13:1, 1-13, DOI: 10.1080/1448837X.2015.1092925
- [3] Khokhar S., A.A. Mohd Zin, A.S. Mokhtar & N. Zareen (2016) Automatic pattern recognition of single and multiple power quality disturbances, Australian Journal of Electrical and Electronics Engineering, 13:1, 43-53, DOI: 10.1080/1448837X.2015.1092932
- [4] Salam Z. (2015) A Simple Online Selective Harmonic Elimination Pulse-Width Modulation Scheme for Voltage Source Inverters, Australian Journal of Electrical and Electronics Engineering, Pages 133-144, DOI:10.1080/1448837X.2010.11464265
- [5] Sarala P., S. F. Kodad, B. Sarvesh (2017), Power Factor Correction with Current Controlled Buck Converter for BLDC Motor Drive. International Journal of Power Electronics and Drive System (IJPEDS) , 2017, Vol. 8, No. 2, pp. 730-738. ISSN: 2088-8694, DOI: 10.11591/ijpeds.v8i2.pp730-738
- [6] Bindu, K.V. & Rabi, Justus. (2015). A Novel Power Factor Correction Rectifier for Enhancing Power Quality. International Journal of Power Electronics and Drive Systems (IJPEDS). 6. 772-780. 10.11591/ijpeds.v6.i4.pp772-780.
- [7] Stepins, D., Jin Huang (2017), J. Effects of Switching Frequency Modulation on Input Power Quality of Boost Power Factor Correction Converter. International Journal of Power Electronics and Drive System (IJPEDS), 2017, Vol.8, No.2, pp.882-899. ISSN 2088-8694. Available from: doi:10.11591/ijpeds.v8i2.pp882-899
- [8] Rani R. A., Shakir Saat, Yusmarnita Yusop, Huzaimah Husin, F. K. Abdul Rahman, A. A. Isa (2016), The Effects of Total Harmonics Distortion for Power Factor. International Journal of Power Electronics and Drive System (IJPEDS), 2016, Vol. 7, No. 2, pp. 543-550. ISSN: 2088-8694.
- [9] Philip C. TODD (1999), unitorde application note, UC 3854 controlled Power factor correction circuit design
- [10] Pacheco, V.M.; de Freitas, L.C.; Vieira, IB., Jr.; Pereira, A.A.; Coelho, E.A.A.; Farias, V.J. (2005) , "An online no-break with power factor correction and output voltage stabilization," Power Electronics, IEEE Transactions on ,vol.20, no.5, pp. 1109-1117
- [11] Grace Chu ; Chi K. Tse ; Siu Chung Wong (2009) "Line-Frequency Instability of PFC Power Supplies IEEE Transactions on Power Electronics" Volume: 24 , Issue: 2, Page s: 469 – 482
- [12] Jian Sun, Min Chen, Kamiar J. Karimi (2008) "Aircraft Power System Harmonics Involving Single-Phase PFC Converters". IEEE Trans. On Aerospace and Electronic Systems, Vol.44, no.1, pp.217-226.
- [13] L.umanand (2013) "power electronics essential and applications" Wiley publication

- [14] Michael O'Loughlin (2012) , Leading-edge modulation improves power-supply efficiency in PFCdesigns,TexasInstruments,05.27.12, Accessed [https://www.eetimes.com/document.asp?doc\\_id=1279671](https://www.eetimes.com/document.asp?doc_id=1279671)
- [15] Bhim Singh ; Sanjeev Singh ; Ambrish Chandra ; Kamal Al-Haddad (2011),IEEE Transactions on Industrial Informatics,Year: , Volume: 7 , Issue: 4,Pages: 540 – 556
- [16] Texas instruments (2015) "UCC2817,UCC2818,UCC3817and UCC3818 BiCMOS Power Factor Preregulator" SLUS395K
- [17] J.P. Noon (2003), "Designing High-Power Factor Off-Line Power Supplies," Texas Instruments Power Supply Design Seminar, SEM-1500
- [18] T. Kaneko, K. Wada, and A. Tokumasu (2015), "Switching-frequency ripple current reduction of DC-link capacitor for a single-phase charger," in Proc. 2015 IEEE 2nd Int. Future Energy Electron. Conf., Taipei, Taiwan, 2015, pp. 1–6